

Hi-TECH 850

Extra-Large Horizontal Turning Center
32" Chucker with Y-Axis





EXTRA-LARGE HORIZONTAL TURNING CENTER 32" CHUCKER

The horizontal turning center perfect for the production of large-size Products and tough materials

Hi-TECH 850 is capable of handling a variety of complex jobs from turning to milling in a single process. Its extra-wide and extra-rigid Turret, the stability provided by the one piece casting bed and box way design are ideal for turning of large sized workpieces.

1 Shaft / Sample / SM45C 2 Box way slide
3 Long Boring Bar \varnothing 80 / L800mm 4 Customization Design

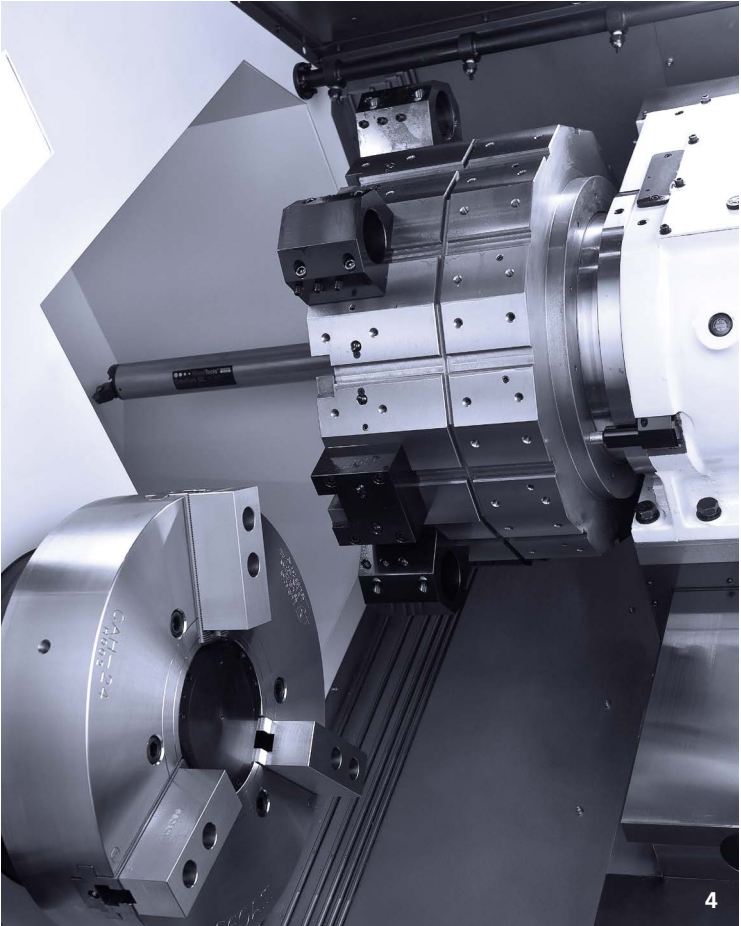
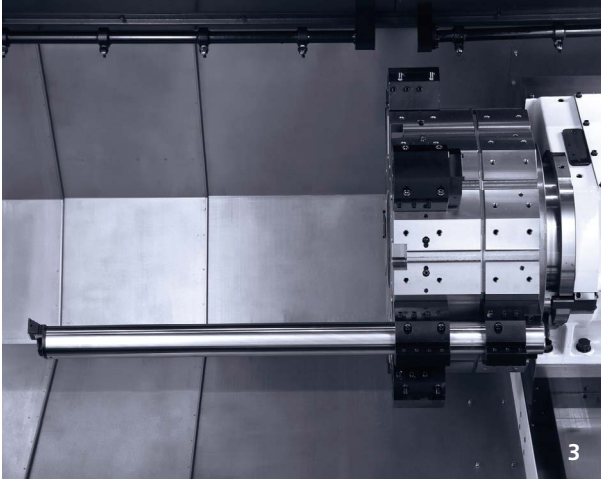
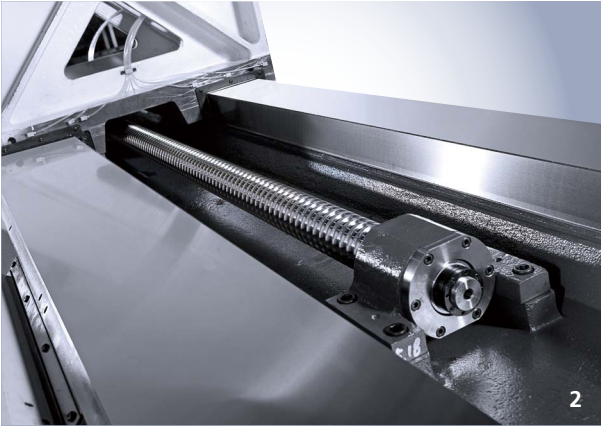

HIGH PERFORMANCE EXTRA-LARGE TURNING CENTER

Hi-TECH 850 has a integrated 45-degree slant bed frame to minimize heat distortion, all guide way are designed as solid Box guide ways to maintain rigidity and precision even during prolonged operations. Its automatic transmission system allows low-speed, high-torque turning as well as high-speed machining, the optional Y-axis ensures process-integrated operations of complex large workpieces in one setting.



EXTRA-LONG BORING BAR

Maximum diameter / length of the boring bar : D = Ø80 mm / L = 800 mm

Maximize your productivity by adding a Y-axis to your Hi-TECH 850 center. This is an ideal option if you want to complete complex processes including turning and milling in a single setting. A added Y-axis will save time and avoid secondary clamping of your part, eliminating down time and increase your profit.

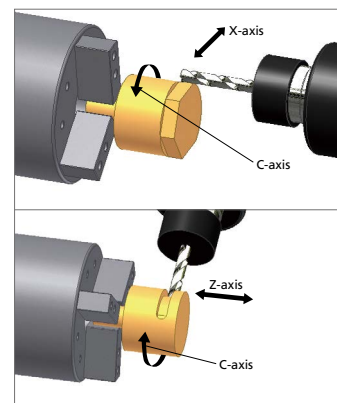
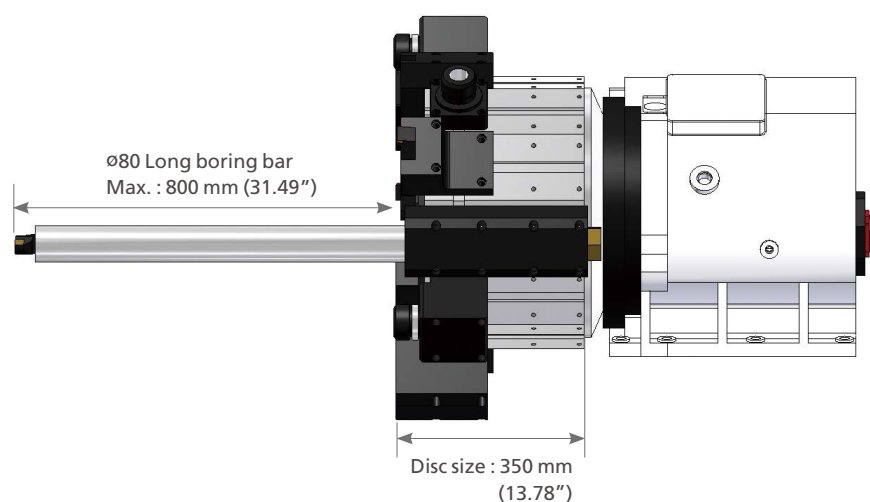

Material	Tool	Gear position	Cutting depth (mm)	Feedrate (mm/rev)	Cutting speed (m/mm)	Tool length (mm)	Roughness [Ra(μm)]
STKM 13C (Ø130 x Ø110 x 1,200)	570-DCLNT-16	M43 (3step / High speed)	0.1	0.1	260	650	1.671
	570-3C-80 1200 DNMG 150604LK (For finishing)					750	1.170

Multi-process milling with Y-axis (YMC)

- Spindle indexing: by 0.0001 degree
- Y-axis stroke: 220(±110)mm [8.66"(±4.33")]

The largest cutting diameter and cutting length in its class (ø825/5,100mm)

The spindle, the tailstock and the steady rest system is designed and built to support heavy, large-diameter workpieces. The integrated 45degree slant bed frame minimizes thermal distortion, all guide ways are in a rectangular box way design, to maintain rigidity and precision even after hours of operation.

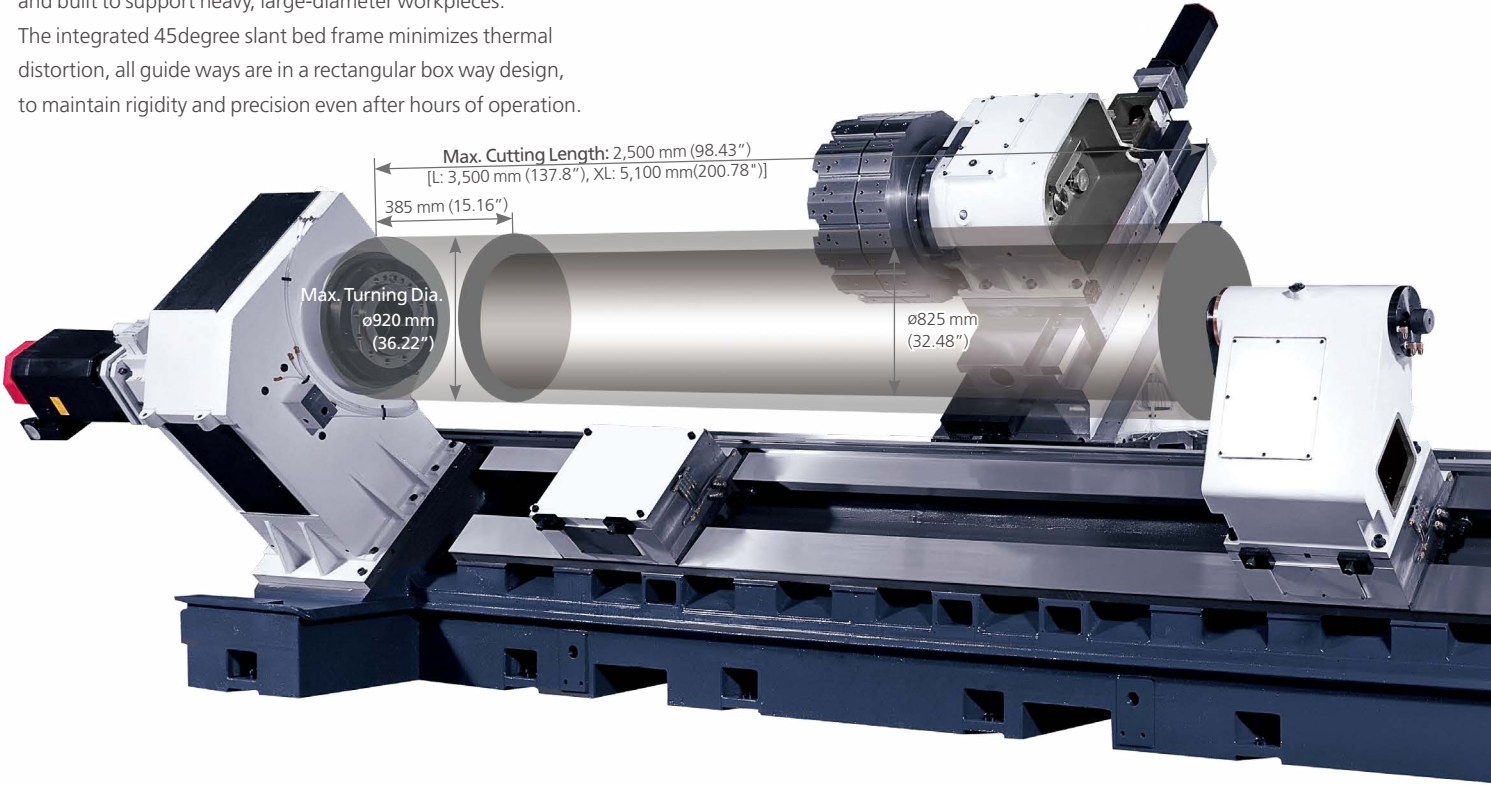

Gear-Driven Spindle System

The four-speed transmission with the high-performance gear decelerator provides high amount of torque at low speed. The bearing assembly is cooled and lubricated by Hwacheon's unique Oil-Jet cooling system, the gear box Temperature is regulated by oil circulation for consistent spindle performance. This four-speed spindle performs best when turning heavy and large workpieces (Max. ø825x5,100mm).

Turning Data

Material : SM45C
 Dimensions : ø400 x 200mm
 Turning speed : V=120 mm/min
 Tool & Insert: CNMG 1606-PR M41 (1st gear)
 power output range

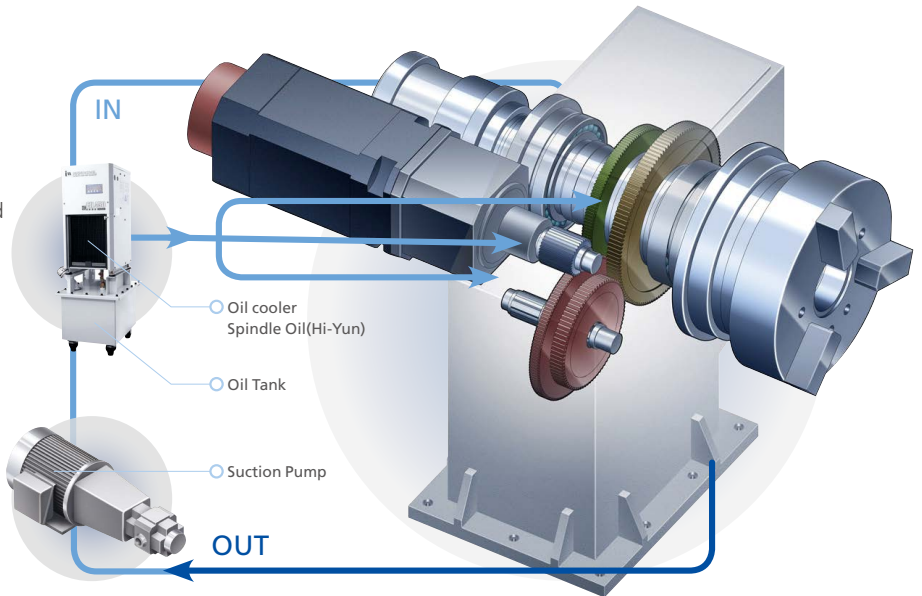

Cutting Depth (mm)	5	6	7	8	9	10
Recommended Feed (mm/rev)	0.82	0.68	0.58	0.51	0.46	0.41
Maximum Feed (mm/rev)	1.3	1.08	0.92	0.81	0.73	0.65



USER FRIENDLY DESIGN, A WIDE RANGE OF OPTIONAL FEATURES

Hi-TECH 850 is designed with the end user in mind. Its user-friendly machine design and a variety of supplementary features ensure a stronger, faster and more precise machining performance.

Best steady rest performance in its class (Option)

Hi-TECH 850 provides up to 2 sets of steady rest, each can hold up to a diameter of $\varnothing 510\text{mm}$ workpiece. The best hydraulic steady rest in its class. The programmable steady rest base can also be ordered separately.

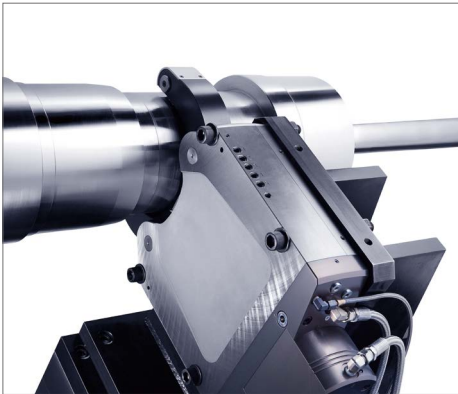

The Programmable Hydraulic Tailstock

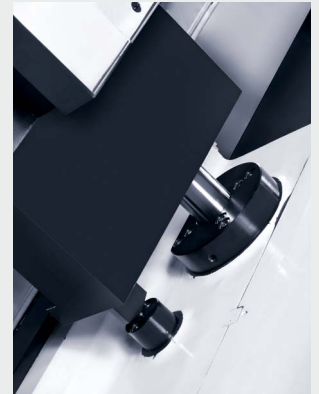

L-HTLD: Hwacheon Lathe Tool Load Detect System (Option)



The Hwacheon Lathe Tool Load Detect System constantly detects and diagnoses the tool load under a process to prevent tool wear and damage, and to keep your machine and tools in optimal shape.

Load Detection Limit 1

Alarm + Feed Hold

> When the LIMIT 1 Alarm sounds, the system holds the feed and the machine goes into standby.

Load Detection Limit 2

Alarm + Machine Stop

> When the LIMIT 2 Alarm sounds, the system stops the machine, and must be reset to operate it.



Product Data

* Unit: mm(inch)

L : Long Bed
XL : Extra Long Bed

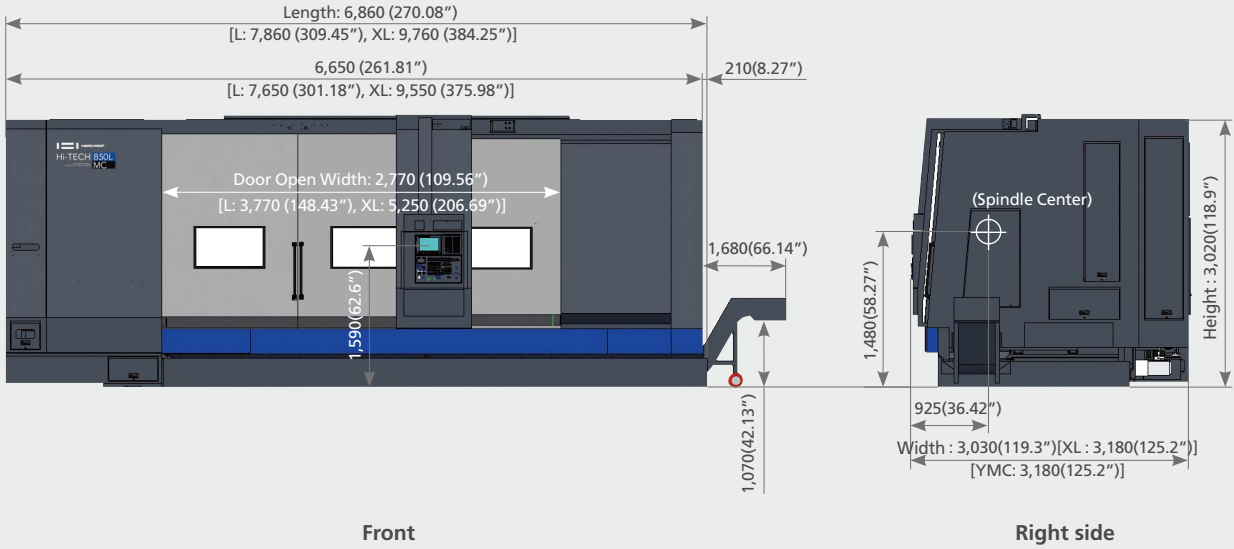

Spindle Power-Torque Diagram

1 / 2 Step (With 24" Chuck)

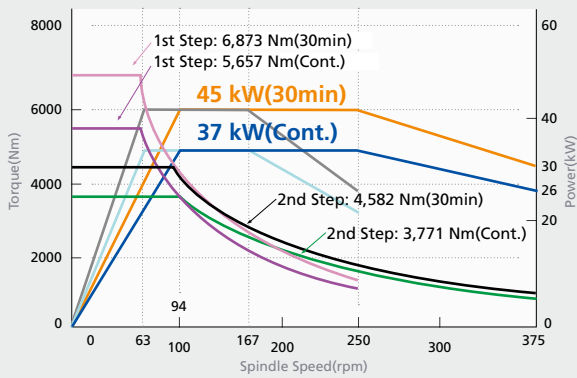

3 / 4 Step (With 24" Chuck)

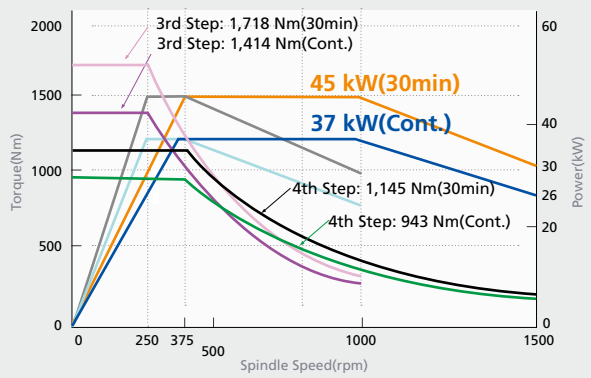

Tool Interference Diagram

※ Unit : mm(inch)

Standard Tool Interference

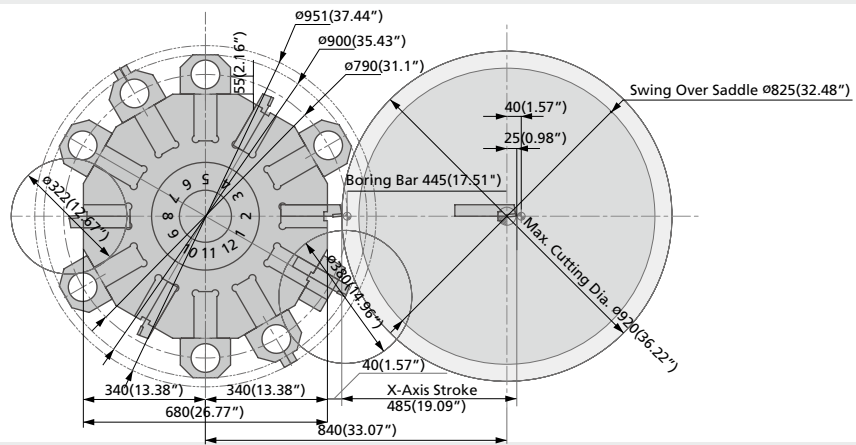

MC Tool Interference

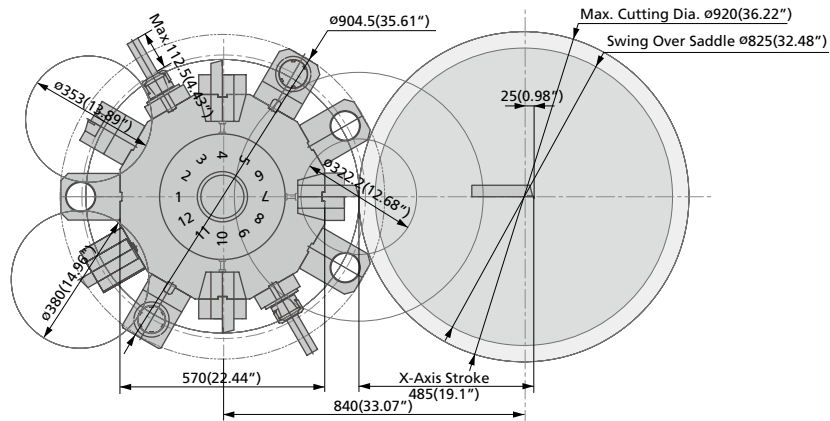

YMC Radial Turnmill Holder

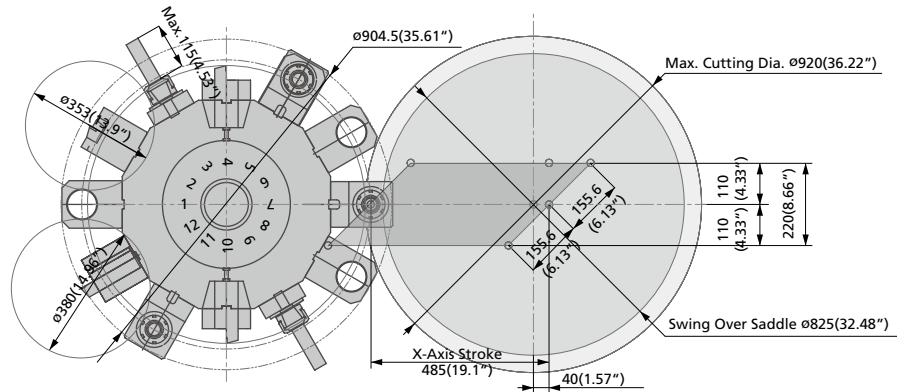

YMC Axial Turnmill Holder

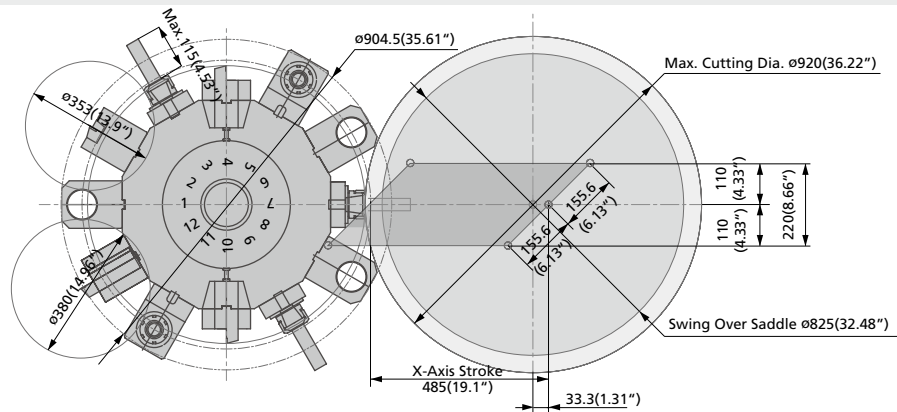

Moving Range
Standard

※Unit: mm(inch)

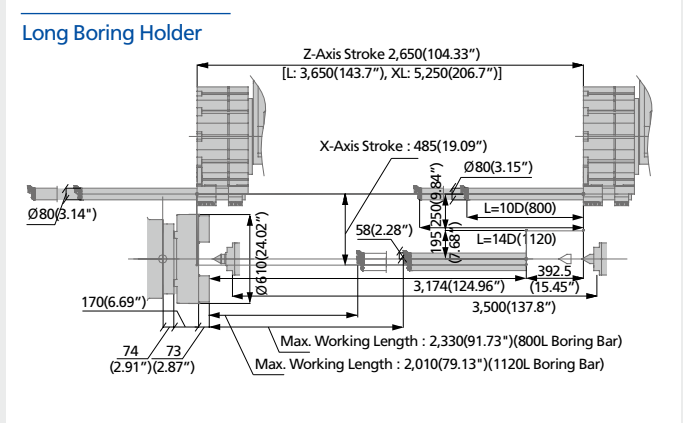
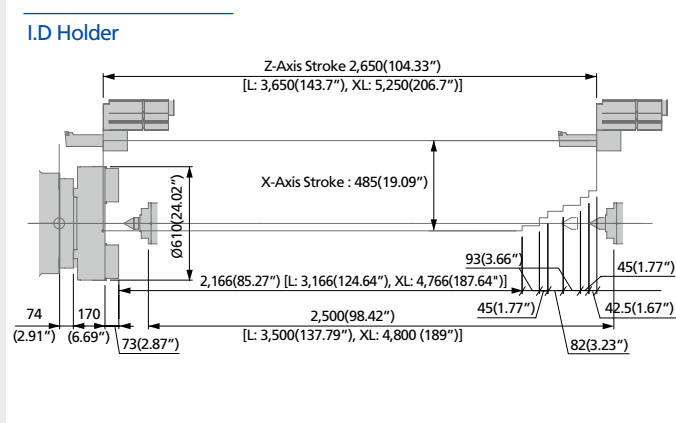
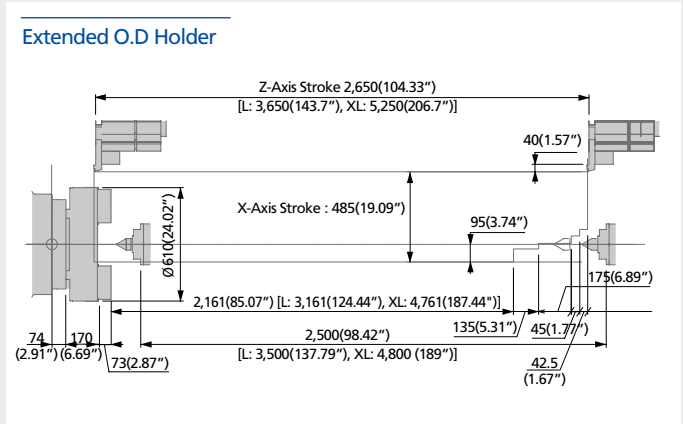
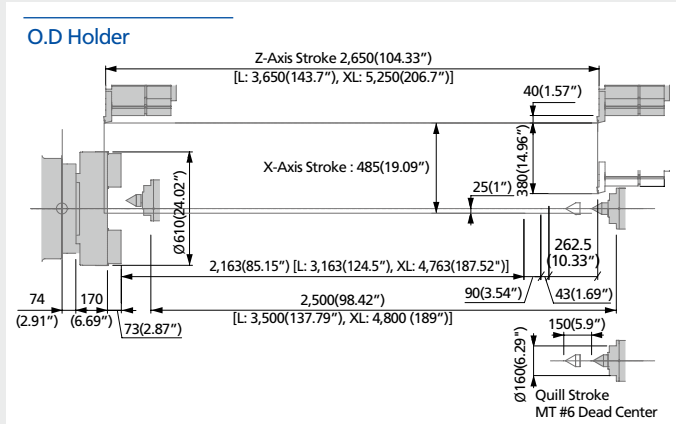

MC

※Unit: mm(inch)

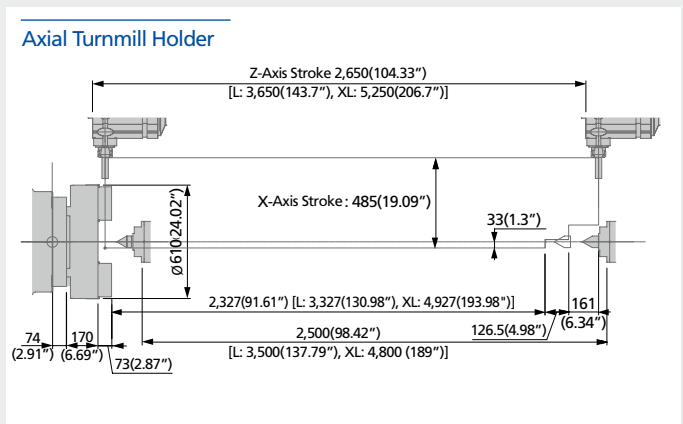
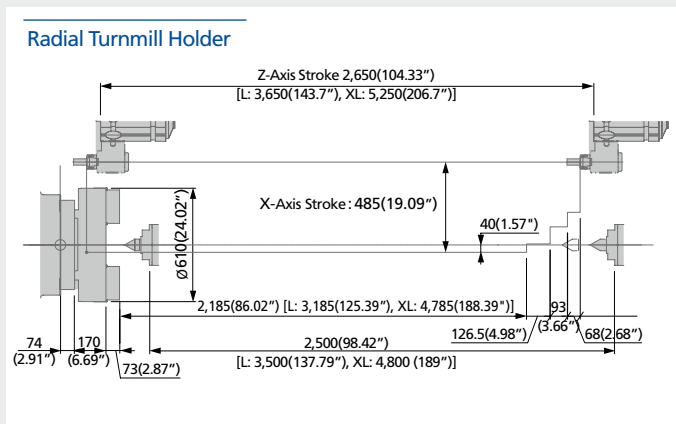
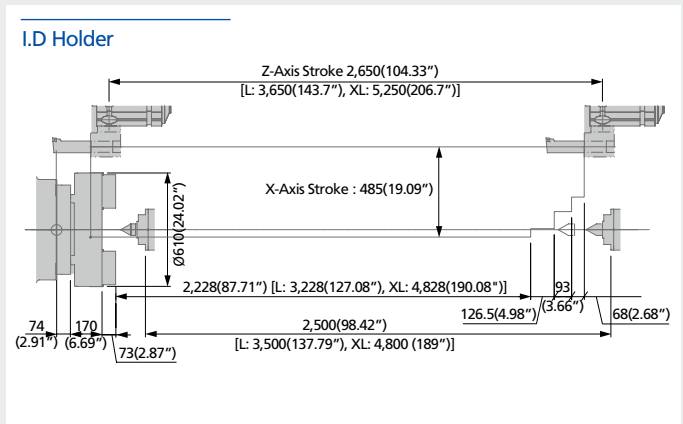
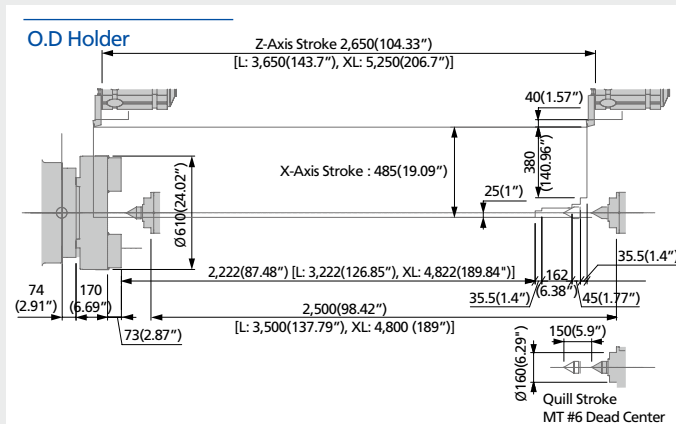

Product Configuration

Each product can be configured to fit your application.

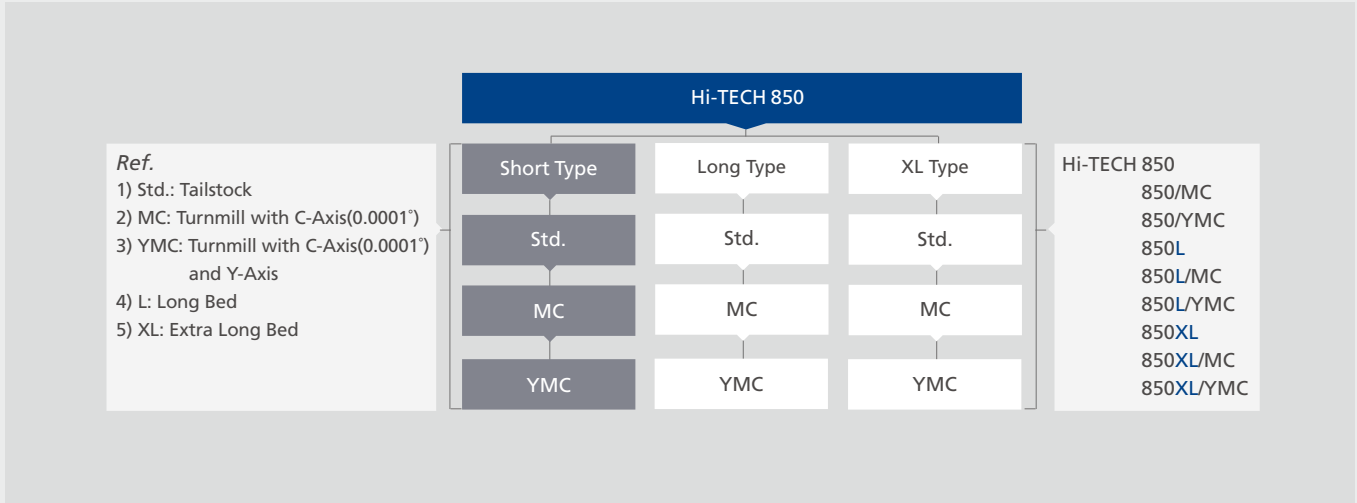

Machine Specifications

ITEM	Hi-TECH 850 SERIES						
	850 / 850MC	850YMC	850L / 850LMC	850LYMC	850XL / 850XLMC	850XLYMC	
Capacity							
Swing over Bed	mm (inch)	Ø1,050 (Ø41.34")					
Max. Cutting Dia. [Cutting Length]	mm (inch)	Ø920 (Ø36.22") [385 (15.16")]					
Standard Cutting Diameter	mm (inch)	Ø380 (Ø14.96")					
Max. Cutting Length [Cutting dia.]	mm (inch)	2,500 (98.42") [Ø825 (Ø32.48")]	3,500 (137.79") [Ø825 (Ø32.48")]		5,100 (200.78") [Ø825 (Ø32.48")]		
Chuck Size (Opt.)	inch	24" / 32"					
Spindle							
Type of Spindle Nose	ASA	A2-15					
Max. Spindle Speed	rpm	1,500 (24"Chuck: 1,400, 32"Chuck: 1,200)					
Through Spindle Hole Diameter	mm (inch)	Ø185 (Ø7.28")					
Max. Bar Size	mm (inch)	Ø164 (Ø6.46")					
Spindle Bearing Inner Diameter	mm (inch)	Ø240 (Ø9.45")					
Spindle Motor	kW (HP)	45 / 37 (60 / 50)					
Turret							
Number of Tool Station	ea	12					
Tool Size	mm (inch)	□32 x Ø80 (□1.25" x Ø3")					
Turret Indexing Time	sec / step	0.3					
Axes							
Rapid Speed (X / Z / Y)	m/min (ipm)	10 / 12 / - (393.7 / 472.4 / -)	10 / 12 / 10 (393.7 / 472.4 / 393.7)	10 / 10 / - (393.7 / 393.7 / -)	10 / 10 / 10 (393.7 / 393.7 / 393.7)	10 / 9 / - (393.7 / 354.3 / -)	10 / 9 / 10 (393.7 / 354.3 / 393.7)
Max. Stroke (X / Z / Y)	mm (inch)	485 / 2,650 / - (19.1" / 104.33" / -)	485 / 2,650 / 220 (19.1" / 104.33" / 8.66")	485 / 3,650 / - (19.1" / 143.7" / -)	485 / 3,650 / 220 (19.1" / 143.7" / 8.66")	485 / 5,250 / - (19.1" / 206.7" / -)	485 / 5,250 / 220 (19.1" / 206.7" / 8.66")
Feed Motor (X / Z / Y)	kW (HP)	6 / 6 / - (8 / 8 / -)	6 / 6 / 7 (8 / 8 / 9.3)	6 / 6 / - (8 / 8 / -)	6 / 6 / 7 (8 / 8 / 9.3)	6 / 9 / - (8 / 12 / -)	6 / 9 / 7 (8 / 12 / 9.3)
Tailstock							
Quill Dia.	mm (inch)	Ø160 (Ø6.3")					
Quill Stroke	mm (inch)	150 (5.91")					
Quill Taper	MT	# 6					
Turnmill							
Spindle Motor	kW (HP)	11/7.5 (15/10)					
Max. Spindle Speed	rpm	2,500					
Max. Drill / Collet Size	mm (inch)	Ø32 (Ø1.25") / ER50					
Min. Index Angle	° (deg)	0.0001°					
Tank Capacity							
Lubrication	ℓ (gal)	12 (3.17)					
Hydraulic	ℓ (gal)	50 (13.21)					
Coolant	ℓ (gal)	400 (105.67)	550 (145.3)		700 (184.9)		
Power Sources							
Electrical Power Supply	kVA	85					
Dimension							
Height	mm (inch)	3,020 (118.9")					
Floor Space (L x W)	mm (inch)	6,860 x 3,030 (270.08" x 119.3")	6,860 x 3,180 (270.08" x 125.2")	7,860 x 3,030 (309.45" x 119.3")	7,860 x 3,180 (309.45" x 125.2")	9,760 x 3,180 (384.25" x 125.2")	
Weight	kg _r (lb _r)	Std.: 22,000 (48,502) MC: 22,500 (49,604)	23,500 (51,809)	Std.: 25,600 (56,438) MC: 26,100 (57,541)	27,100 (59,745)	Std.: 30,000 (66,139) MC: 30,500 (67,241)	32,000 (70,548)
NC Controller							
Fanuc Oi-TF							

Standard and Optional Product Components

Standard Accessories		Optional Accessories	
• Coolant System	• Tailstock (MT#6)	• Air Blower	• Mist Collector
• Chuck Pressure Compensation	- Tailstock Body Program	• Air Gun	• NC Cooler
• Door Interlock	- Tailstock Quill Program	• Arbitrary Speed Threading	• Oil Skimmer
• Dual Pressure (C-axis brake)	• Tooling System	• Chip Conveyor & Box, Side Type	• Programmable Hy'd Steady Rest Base (Max. 2 Pieces)
• Foot Switch	• Tool Holder for Long Boring Bar, 1 Set	• Chuck Clamp/Unclamp Confirm Switch	• Chuck Pressure Check Switch
• High Pressure Coolant Pump, 0.6 MPa	• Tool Kit & Box	• Coolant Gun	• Set of Hard Jaw (24" / 32")
• Hydraulic Cylinder	• Work Light	• Dual Pressure (Chuck)	• Set of Soft Jaw (24" / 32")
• Hydraulic Unit	• 10.4" Color LCD	• Function of Y-axis (±110mm)	• Steady Rest Set (Max. Ø510mm)
• Leveling Bolt & Plate		• High Pressure Coolant Pump, 1.5/ 3/ 7 MPa	• Tool & Work Counter, External / Internal
• Lubrication System		*For 7 MPa, only water soluble coolants are available	• Tool Life Management
• Manual Guide i		• Hydraulic Chuck, 24" / 32"	• Tool Presetter (Automatic)
• Operation Manual & Parts List		• L-HTLD	• Transformer
• Signal Lamp with 3 Colors (R, G, Y)		(Lathe-Hwacheon Tool Load Detect)	• Turnmill Function Including C-axis (0.0001°)
• Spindle Air Curtain		• Linear Scale (X/ Y/ Z)	• Turnmill Holder, Axial / Radial
• Spindle Cooling System		• Long Boring Bar Holder (Ø100)	• U-Drill Holder
• Standard Turret, 12 Stations			• 15" Color LCD (only FANUC)

NC Specifications [Fanuc Oi-TF]

※ - : Not available S : Standard O : Option

ITEM	SPECIFICATION	Std.	MC	YMC
Controlled axis				
Controlled axis (Cs axis)	2-Axes	2-Axes	3-Axes	4-Axes
Simultaneously controlled axes	2-Axes	2-Axes	3-Axes	4-Axes
Least input increment	0.001mm, 0.0001deg, 0.0001inch	S	S	S
Least input increment 1/10	0.0001mm, 0.00001inch	O	O	O
inch/metric conversion	G20, G21	S	S	S
Stored stroke check 1,2,3		S	S	S
Mirror image		S	S	S
Backlash compensation		S	S	S
Operation				
Automatic & MDI operation		S	S	S
Program number search		S	S	S
Sequence number search		S	S	S
Dry run, single block		S	S	S
Manual handle feed	1Unit	S	S	S
Manual handle feed rate	x1, x10, x100	S	S	S
Interpolation function				
Positioning	G00	S	S	S
Linear interpolation	G01	S	S	S
Circular interpolation	G02, G03	S	S	S
Dwell (Per seconds)	G04	S	S	S
Polar coordinate interpolation	G12.1 / G13.1	-	S	S
Cylindrical interpolation	G7.1	-	S	S
Threading / Continuous threading	G32	S	S	S
Multiple threading / Threading Retract		S	S	S
Variable lead threading	G34	S	S	S
Reference position return 1st	G28	S	S	S
Reference position return check	G27	S	S	S
2,3,4th reference position return	G30	S	S	S
Arbitrary speed threading		O	O	O
Feed function				
Rapid traverse override	F0, F25, F50, F100	S	S	S
Feed per minute (mm/min)	G98	S	S	S
Feed per revolution (mm/rev)	G99	S	S	S
Rapid traverse bell-shaped acceleration/deceleration		S	S	S
Feedrate override	0-150 %	S	S	S
Jog feed override	0-1,260 mm/min	S	S	S
Tool function / compensation				
Tool function	T4-digits	S	S	S
Tool offset pairs	128 pairs	S	S	S
Tool nose radius compensation		S	S	S
Tool geometry / wear compensation		S	S	S
Tool life management		O	O	O
Automatic tool offset	Tool presetter option is required	S	S	S
Direct input tool offset value measured B	Tool presetter option is required	S	S	S
Others				
Display unit	10.4" Color LCD	S	S	S

ITEM	SPECIFICATION	Std.	MC	YMC
Program input				
Tape code	EIA / ISO	S	S	S
Optional block skip	9 ea	S	S	S
Program number	O4-Digits	S	S	S
Sequence number	N8-Digits	S	S	S
Decimal point programming		S	S	S
Coordinate system setting	G50	S	S	S
Coordinate system shift		S	S	S
Workpiece coordinate system	G54-G59	S	S	S
Workpiece coordinate system preset	G92.1	S	S	S
Direct drawing dimension programming		S	S	S
G code system	A	S	S	S
Programmable data input	G10	S	S	S
Sub program call	10 folds Nested	S	S	S
Custom macro B		S	S	S
Addition of custom macro -common variables	#100-#199, #500-#999	S	S	S
Canned cycles		S	S	S
Multiple repetitive cycle		S	S	S
Multiple repetitive cycle II		S	S	S
Canned cycles for drilling		S	S	S
Manual Guide i		S	S	S
Spindle speed function				
Constant surface speed control	G96 / G97	S	S	S
Spindle override	50-120 %	S	S	S
Spindle orientation		S	S	S
Rigid tapping		O	S	S
Editing operation				
Part program storage length	1,280m (512 kB)	S	S	S
Number of register able programs	400 ea	S	S	S
Background editing		S	S	S
Extended part program editing		S	S	S
Play back		S	S	S
Operation / Display				
Clock function		S	S	S
Self-diagnosis function		S	S	S
Alarm history display / Help function		S	S	S
Run hour and parts count display		S	S	S
Graphic function		S	S	S
Dynamic graphic display		O	O	O
Multi-language display	Korean, English, German, French, Italian, Chinese, Spanish, Portuguese, Polish, Hungarian, Swedish, Russian	S	S	S
Data input/output				
Reader / Puncher interface CH1, CH2	RS232C	S	S	S
Ethernet interface		S	S	S
Memory card interface		S	S	S
USB card interface		S	S	S

Hwacheon Global Network

 Hwacheon Headquarter  Hwacheon America  Hwacheon Europe  Hwacheon Asia



HWACHEON

Please contact us for product inquiries.

www.hwacheon.com

The product design and specifications may change without prior notice.
Read the operation manual carefully and thoroughly before operating the product,
and always follow the safety instructions and warnings labels attached on the surfaces of the machines.

HEAD OFFICE

HWACHEON MACHINE TOOL CO., LTD.

123-17, HANAMSANDAN 4BEON-RO, GWANGSAN-GU, GWANGJU, KOREA
TEL: +82-62-951-5111 FAX: +82-62-951-0086

SEOUL OFFICE

46, BANGBAE-RO, SEOCHO-GU, SEOUL, KOREA
TEL: +82-2-523-7766 FAX: +82-2-523-2867

USA

HWACHEON MACHINERY AMERICA, INC.

555 BOND STREET, LINCOLNSHIRE, ILLINOIS, 60069, USA
TEL: +1-847-573-0100 FAX: +1-847-573-9900

SINGAPORE

HWACHEON ASIA PACIFIC PTE. LTD.

21 BUKIT BATOK CRESCENT, #08-79 WCEGA TOWER,
658065, SINGAPORE
TEL: +65-6515-4357 FAX: +65-6515-4358

VIETNAM

HWACHEON MACHINE TOOL VIETNAM CO., LTD.

UNIT 507, 5TH FLOOR, LOT T2-4, D1 ROAD, SAIGON HI-TECH PARK,
TAN PHU WARD, DISTRICT 9, HO CHI MINH CITY, VIETNAM
TEL: +84 (0)28-2253-2613 FAX: +84 (0)28-2253-2614

GERMANY

HWACHEON MACHINERY EUROPE GMBH

JOSEF-BAUMANN STR. 25, 44805, BOCHUM, GERMANY
TEL: +49-234-912-816-0 FAX: +49-234-912-816-60

INDIA

HWACHEON MACHINE TOOL INDIA PTE. LTD.

103, GULMOHAR CENTRE POINT, 34/A, WADGAON SHERI,
PUNE 411 014, INDIA
TEL: +91-20-6560-0168

CHINA

HWACHEON MACHINE TOOL CHINA CO., LTD.

B03A LIANGUAN JUHE INTERNATIONAL HARDWARE CITY, NO.
143 ZHENANZHONG ROAD, JINXIA, CHANGAN TOWN,
DONGGUAN CITY, GUANDONG PROVINCE, CHINA #523852
TEL: +86-769-8932-0601 FAX: +86-769-8932-0602